

A hand is shown holding several small, round marbles, some black and some white, in the foreground. In the background, a wooden xylophone structure is visible, with a red surface underneath. The overall scene is set against a red background.

xyloba

Die Kugelbahn, die Musik macht.
The marble run, that makes music.

Anleitungsheft Xyloba melodia folksongs 1 und 2
Instruction book Xyloba melodia folksongs 1 and 2

Herzlich Willkommen in der Welt von Xyloba!

Xyloba ist die Kugelbahn, die Musik macht. Das Stecksystem von Xyloba ermöglicht eine fast unbegrenzte Anzahl von verschiedenen Aufbauvarianten. Zusätzlich zum Bauspass kann mit Xyloba Musik komponiert werden. In den Bahnverlauf werden unterschiedlich hohe Klangplatten eingeschoben. Sie bestimmen die Melodie. Beim Heruntersausen prallt die Kugel an die einzeln befestigten Klangplatten. Unterschiedlich lange Schienen erzeugen den Rhythmus.

Für kleine und grosse Konstrukteure und Komponisten, die bereits erste Erfahrungen mit Xyloba gemacht haben, sind die Xyloba Melodienkästen *melodia* genau das Richtige. Damit lassen sich die Melodienanfänge bekannter Lieder aufbauen und abspielen - musikalischer Bauspass für die ganze Familie.

Lust auf „mehr“?

Die Melodienanfänge lassen sich ganz leicht komplettieren. Unter www.xyloba.ch/de/xylocalc gibt es auf Knopfdruck die Liste der benötigten Bauteile.

Welcome to the world of Xyloba!

Xyloba is the marble run that makes music. The simple interlocking Xyloba system allows an almost unlimited number of variations. The fun really begins when, in addition to building, one starts composing. Carrillon notes of various pitches can be built into the marble run. Tracks of different lengths correspond to note lengths: minims, crotchets and quavers. Melodies are composed by arranging the way the marbles hit these metal sound modules.

For big and small builders and composers who have already taken their first steps with Xyloba, the Xyloba *melodia* melody boxes fit the bill exactly. They can be set up to play the first lines of a variety of familiar songs - Musical building fun for all the family.

Want more?

It's easy to add more songs to your list; at www.xyloba.ch/de/xylocalc a list of the parts you need is only a mouseclick away.

Xyloba melodia folksongs 1 und 2 (Melodienanfänge / first lines of familiar songs)



Xyloba melodia 1+2 , Sur le pont, Seite 6



Xyloba melodia 1+2, Der Mond ist aufgegangen, Seite 7



Xyloba melodia 1+2, Oh, when the Saints, Seite 8



Xyloba melodia 1+2, Stille Nacht, Silent Night Seite 9



Xyloba melodia 2, Frère Jacques, Seite 10



Xyloba melodia 2, Row, row, row your boat, Seite 11



Xyloba melodia 2, Summ, summ, summ, Seite 12



Xyloba melodia 2, Bella Bimba, Seite 13



Xyloba melodia 2, Happy Birthday, Seite 14



Xyloba melodia 2, Weisst du, wieviel Sternlein stehen, Seite 15



Xyloba melodia 2, Hänschen klein, Seite 16



Xyloba melodia 2, L'inverno, Seite 17

Bauanleitung / construction guidance

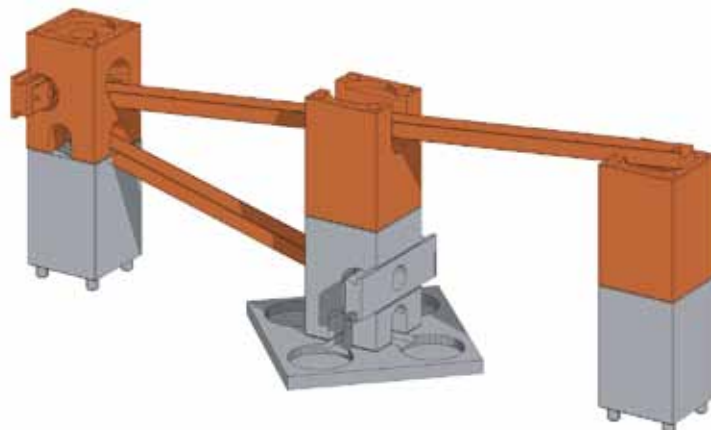
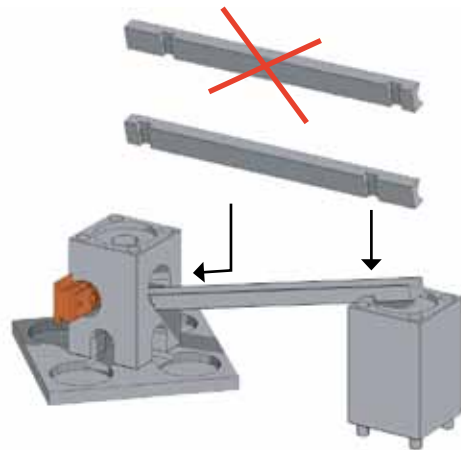
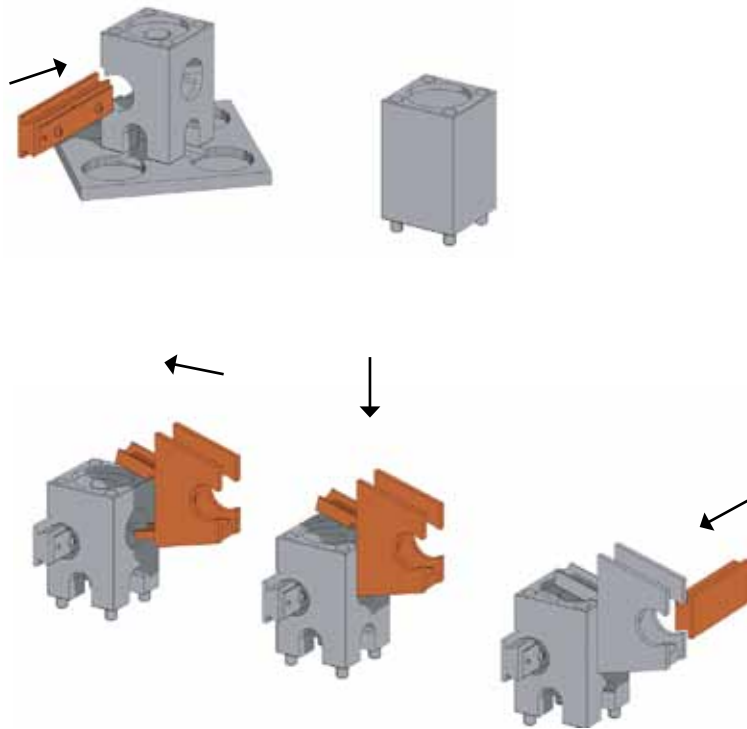

Sur le pont d'Avignon (Melodienanfang / first lines of familiar songs)

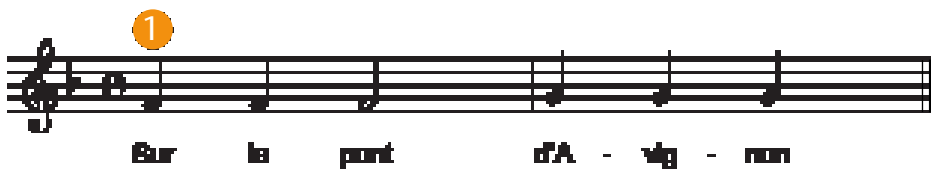

melodia folksongs 1

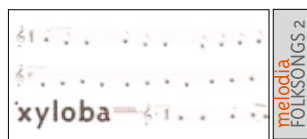

melodia folksongs 2

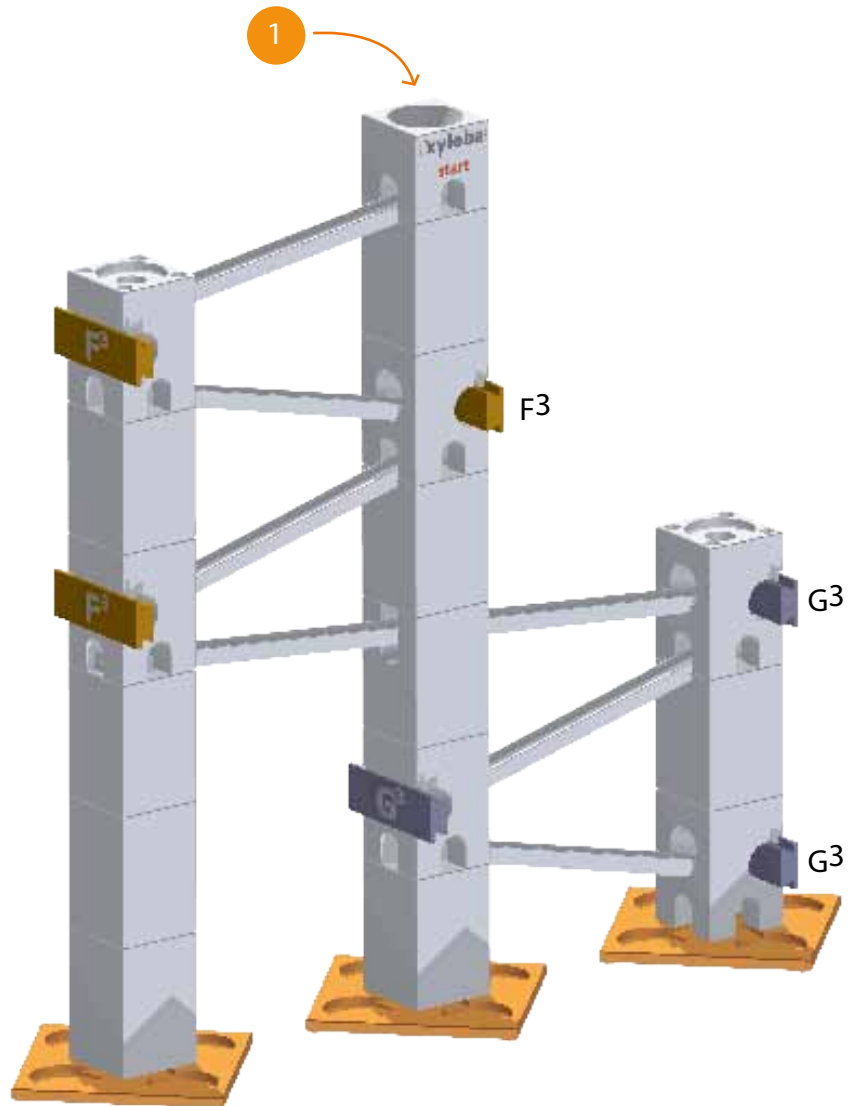

Diese Bauteile werden benötigt / required:

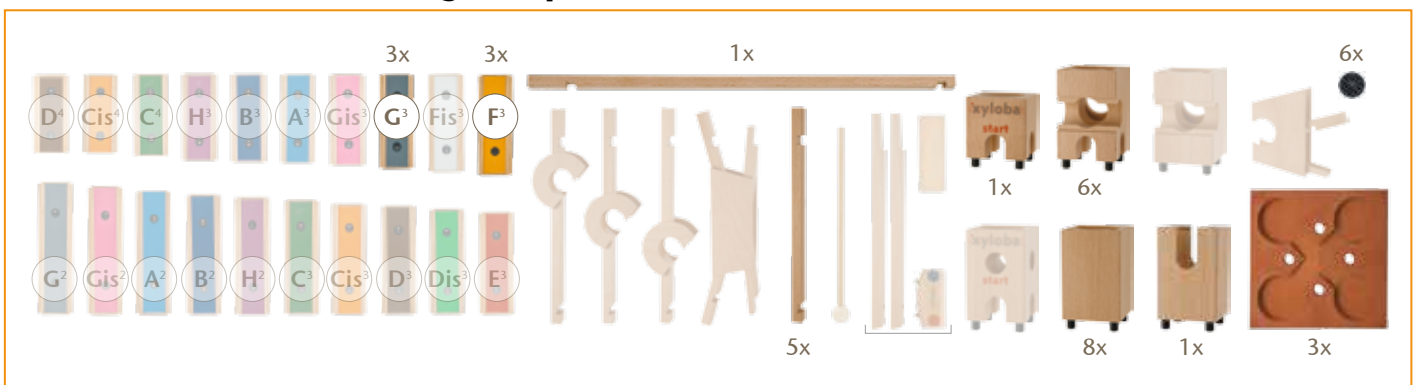

Der Mond ist aufgegangen (Melodienanfang / first lines of familiar songs)



melodia folksongs 1

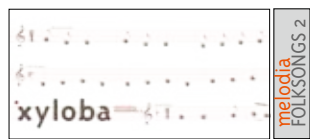

melodia folksongs 2



Diese Bauteile werden benötigt / required:

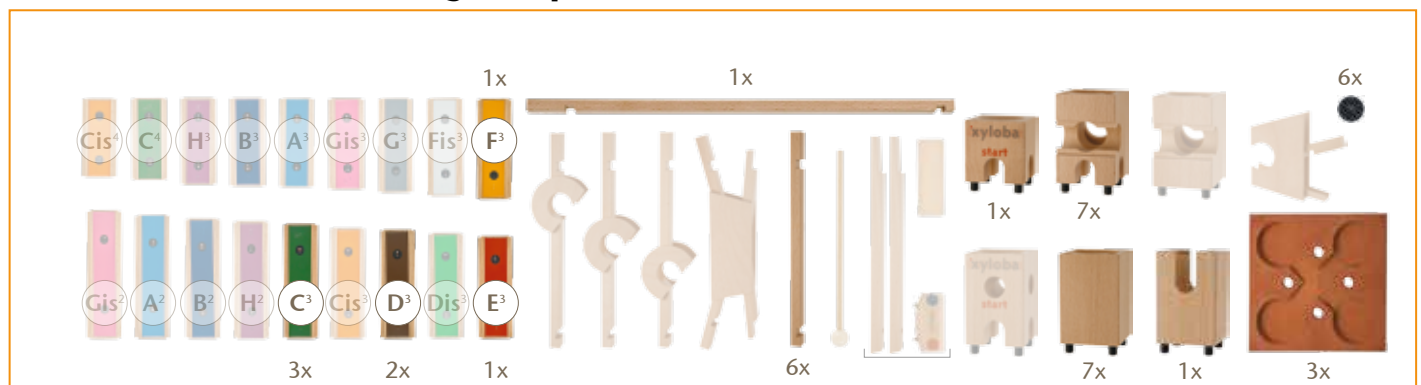

Oh, when the Saints (Melodienanfang / first lines of familiar songs)

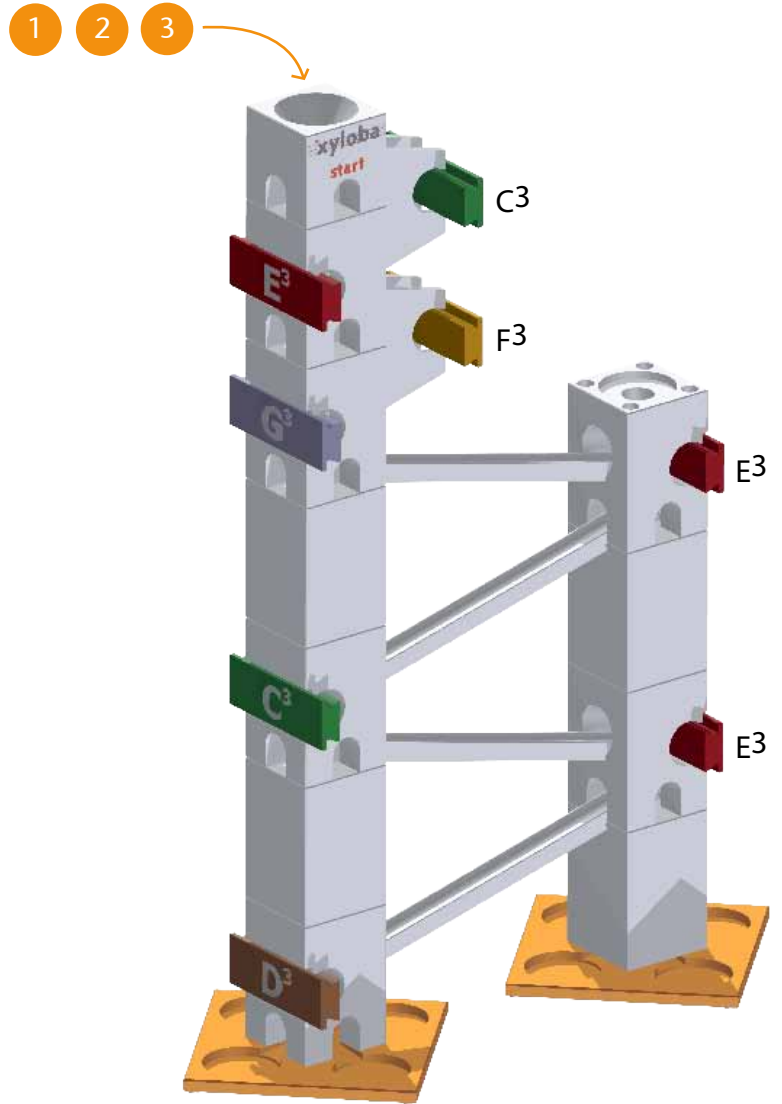
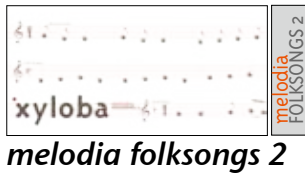
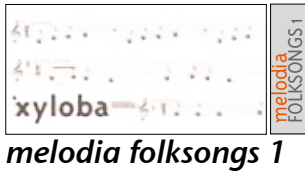
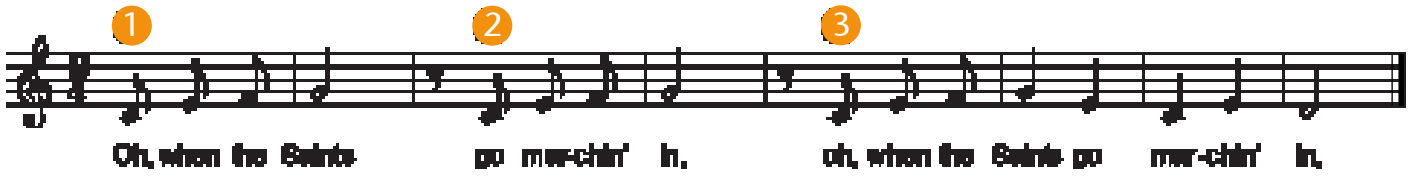

Diese Bauteile werden benötigt / required:

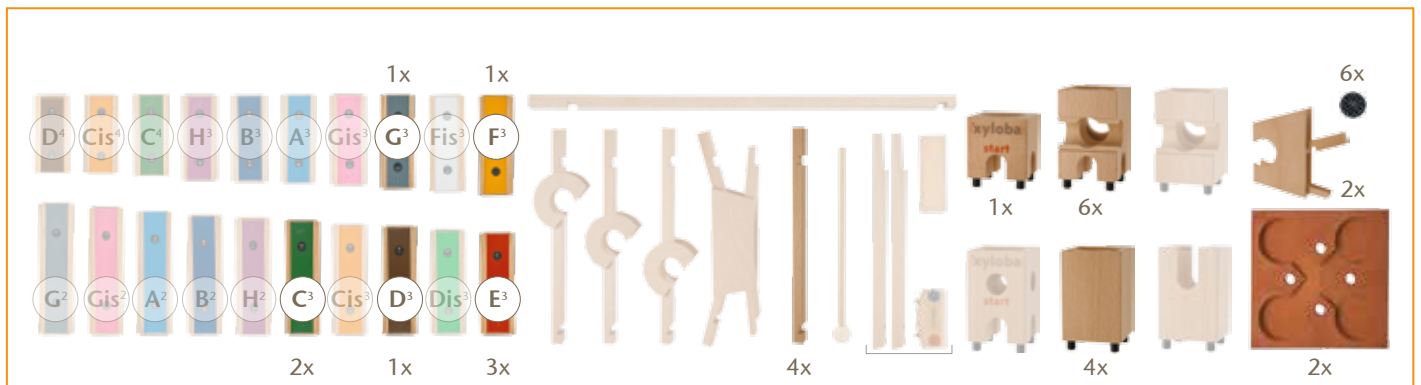

Frère Jacques (Melodienanfang / first lines of familiar songs)

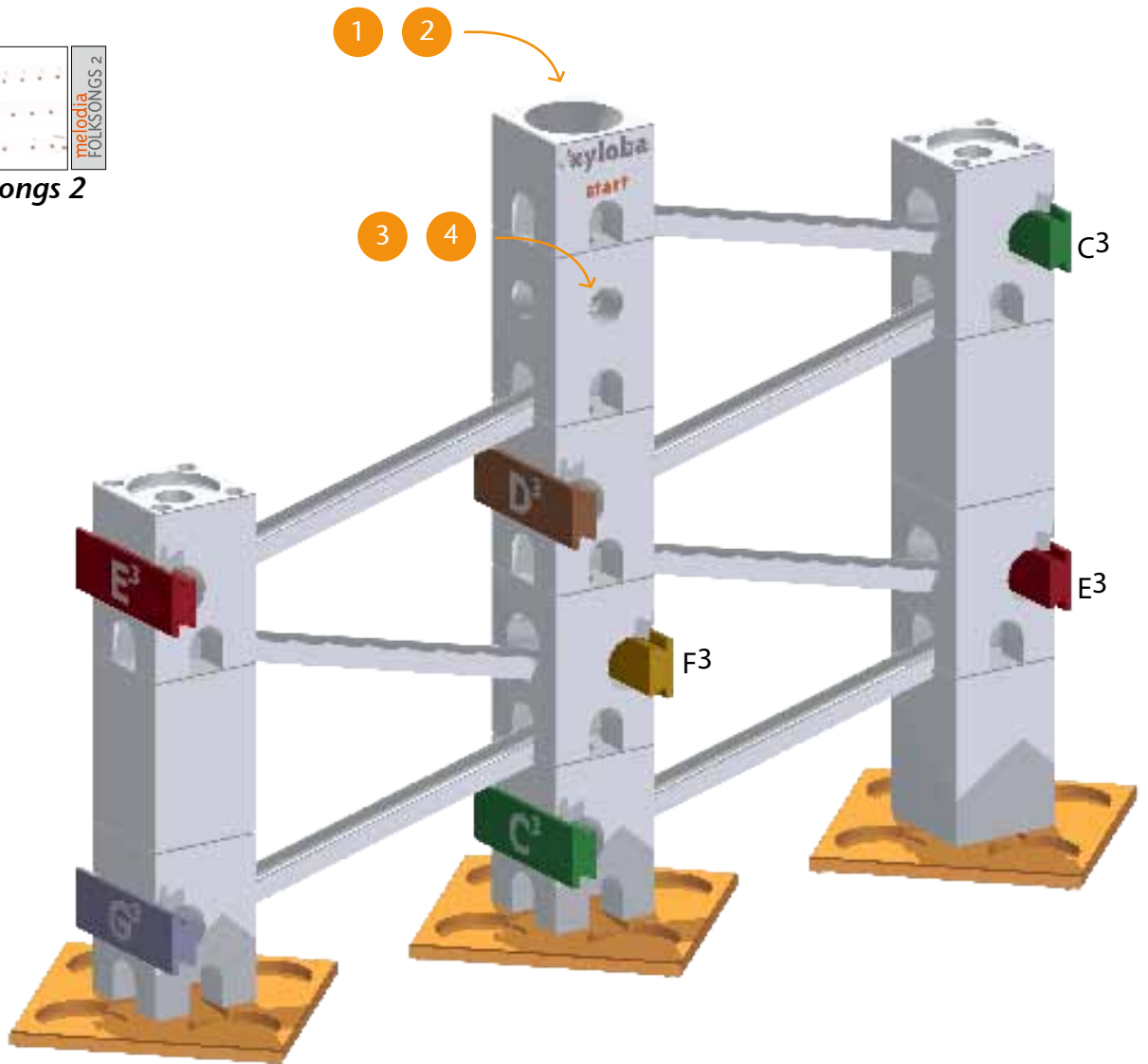
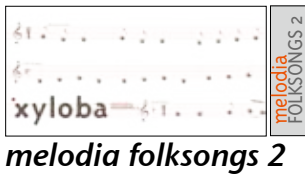
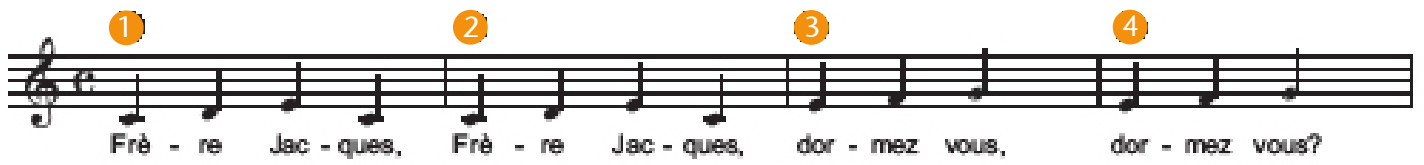

Diese Bauteile werden benötigt / required:

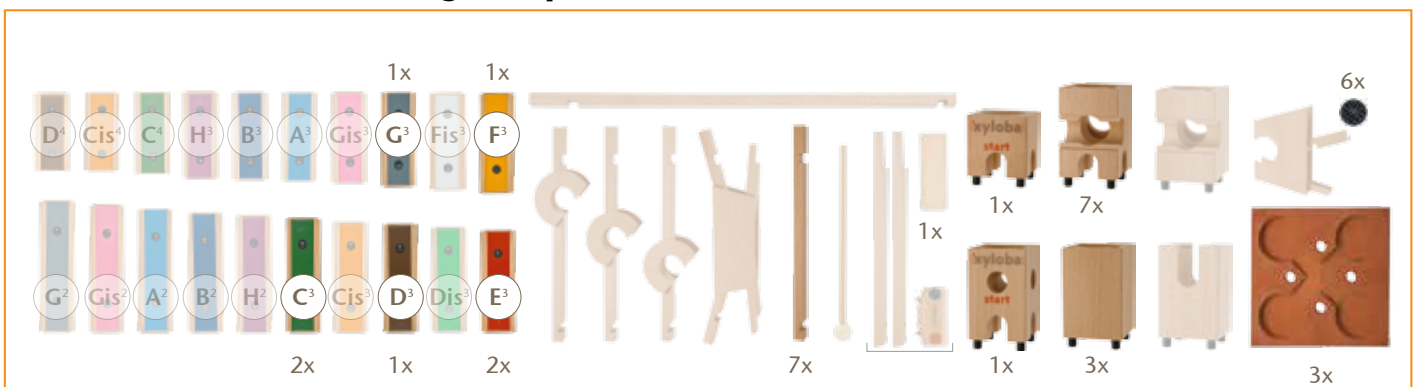

Row, row, row your boat (Melodienanfang / first lines of familiar songs)

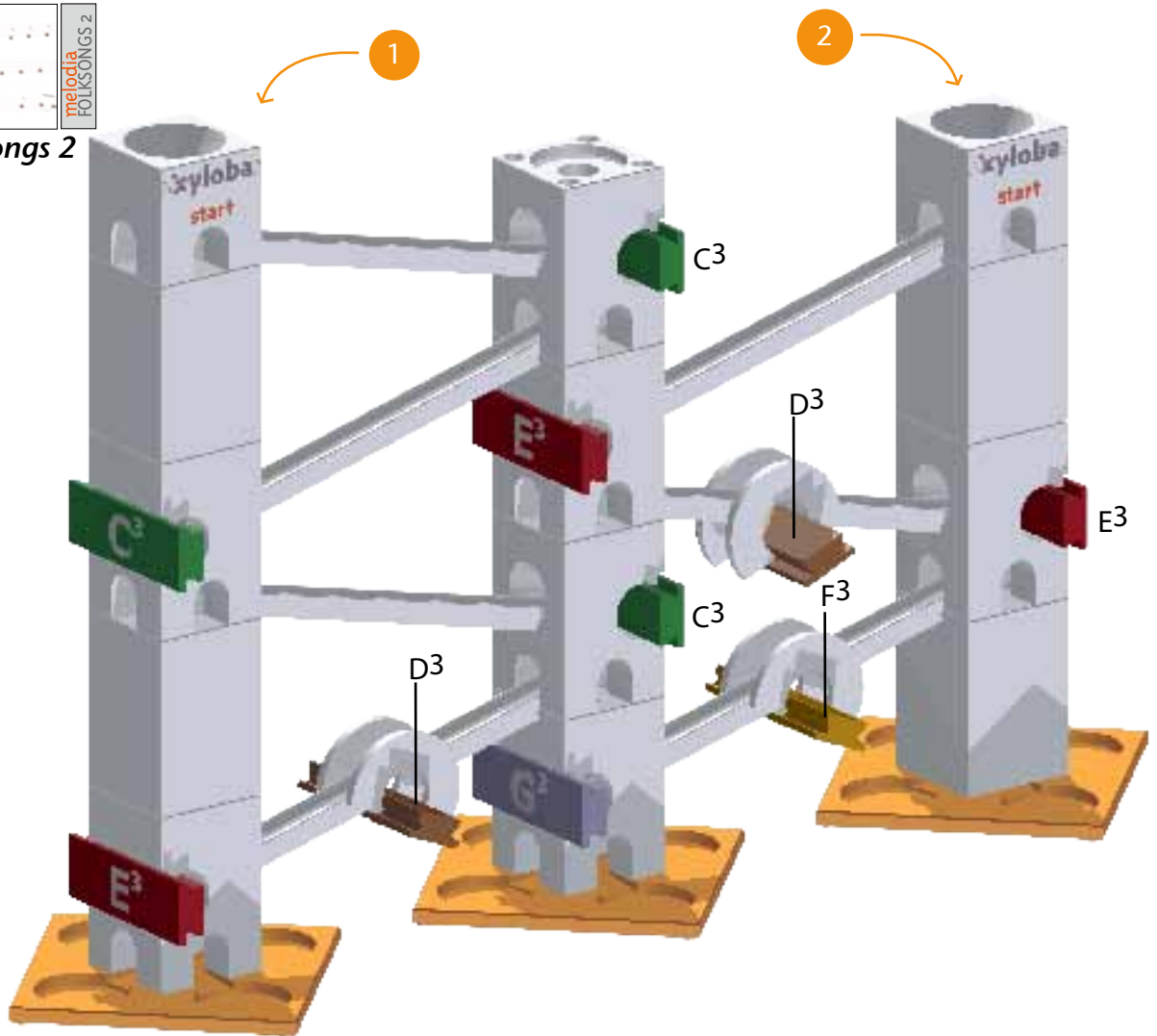
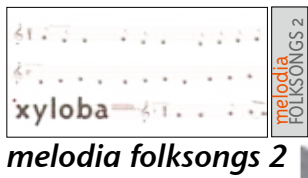
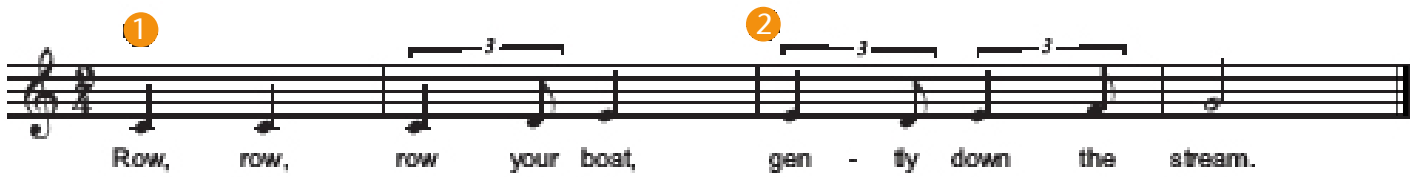

Diese Bauteile werden benötigt / required:

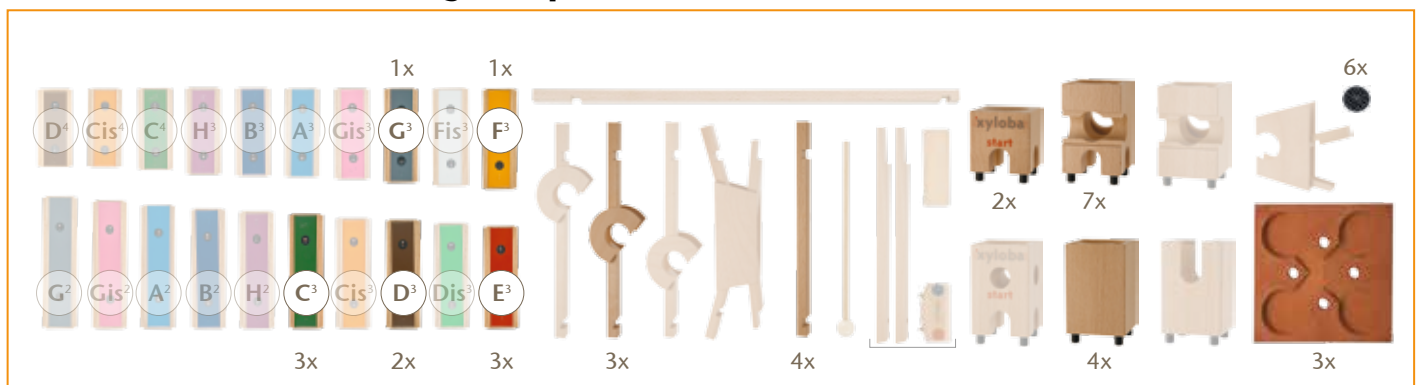

Summ, summ, summ (Melodienanfang / first lines of familiar songs)

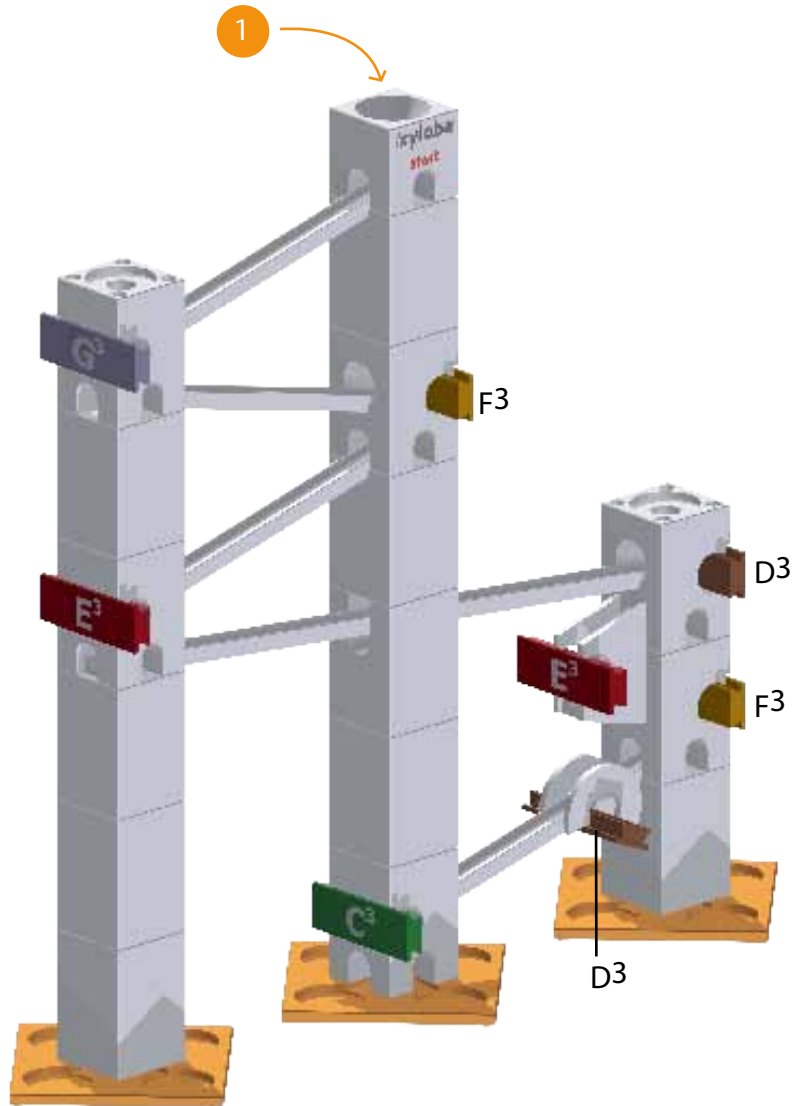
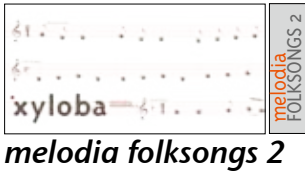

Diese Bauteile werden benötigt / required:

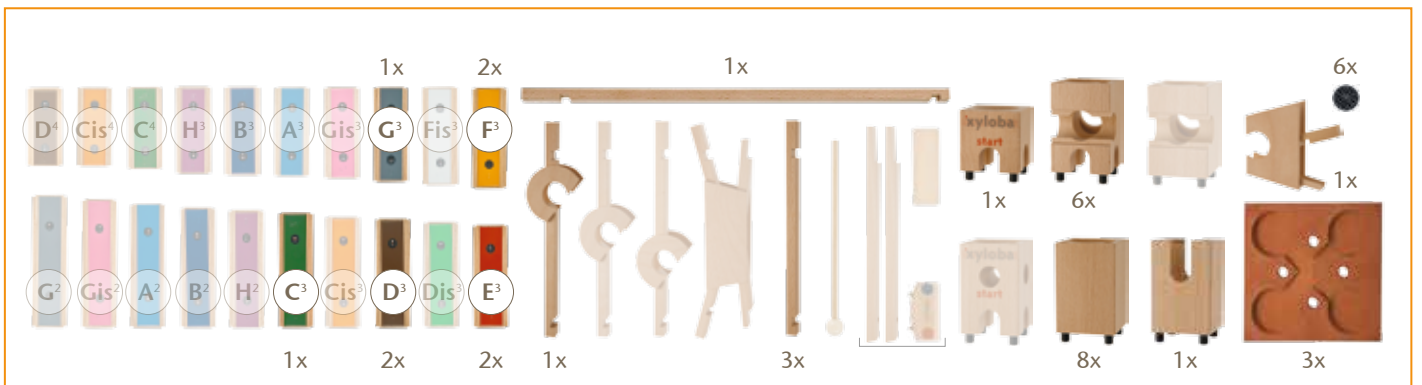

Bella Bimba (Melodienanfang / first lines of familiar songs)

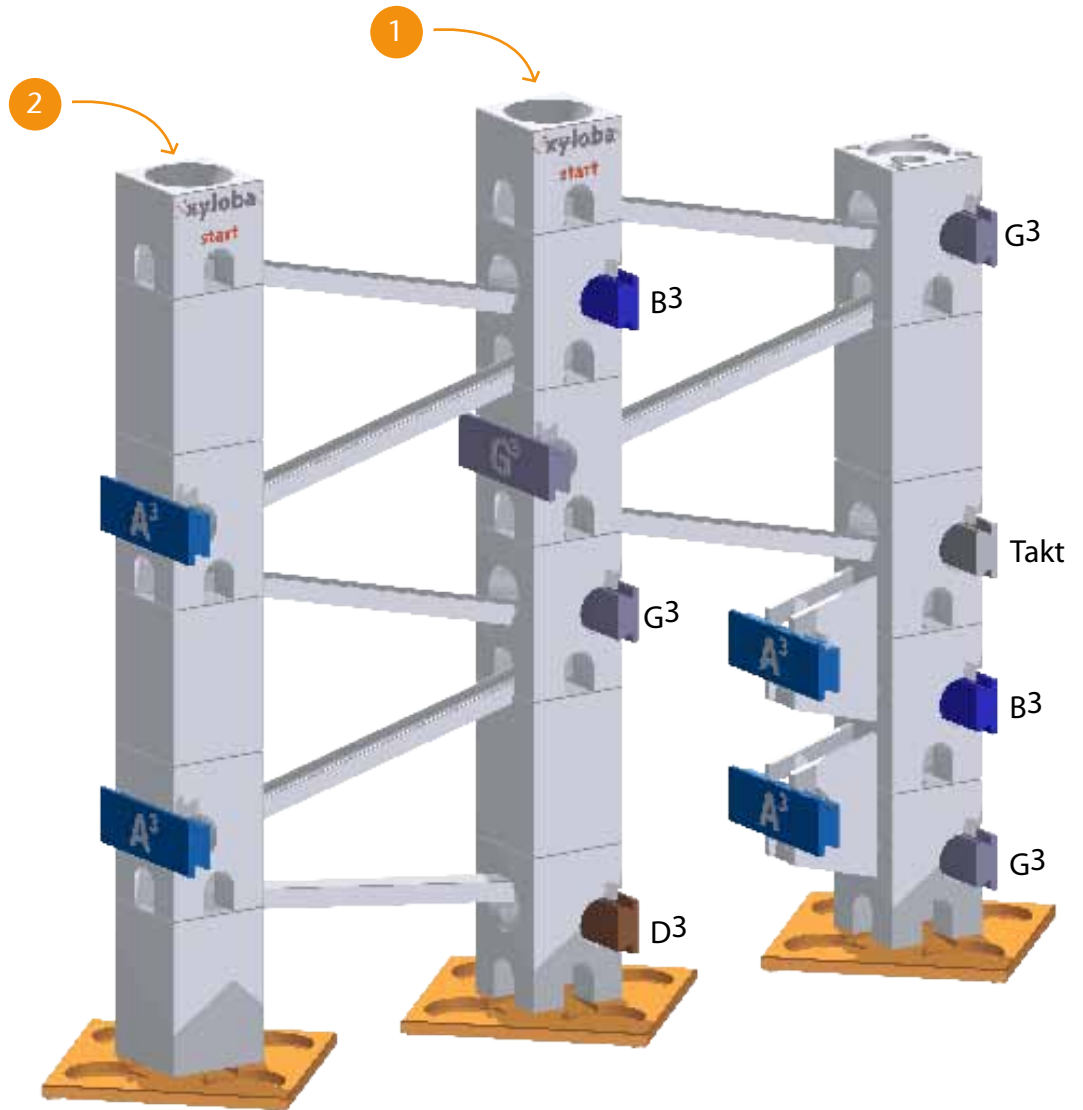
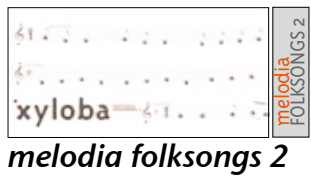
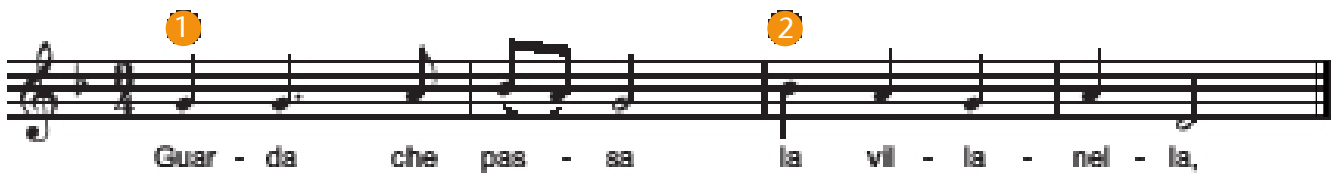

Diese Bauteile werden benötigt / required:

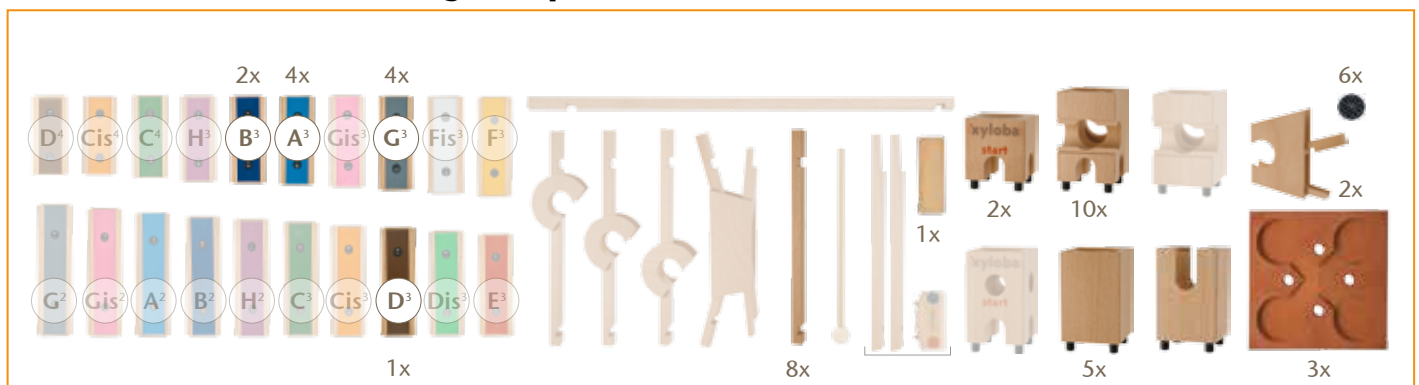

Hänschen klein (Melodienanfang / first lines of familiar songs)

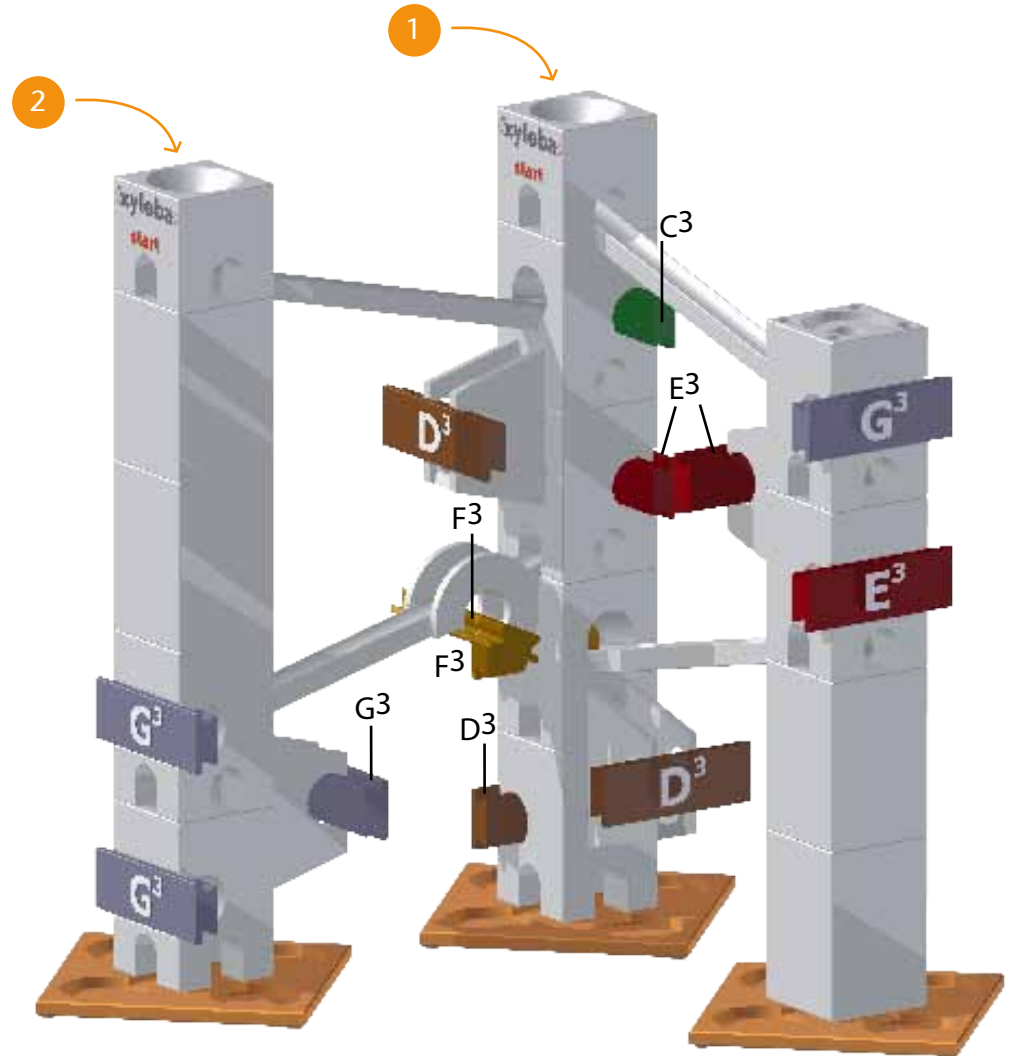
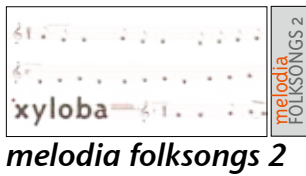
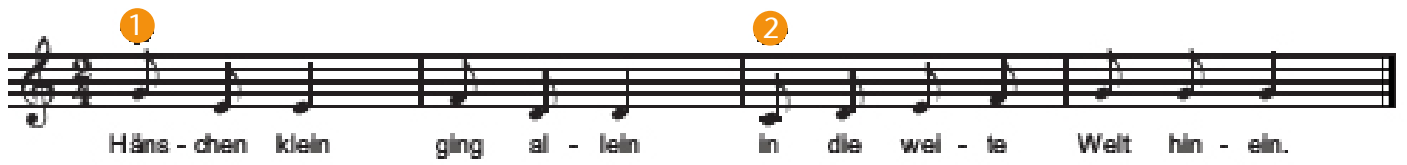

Diese Bauteile werden benötigt / required:

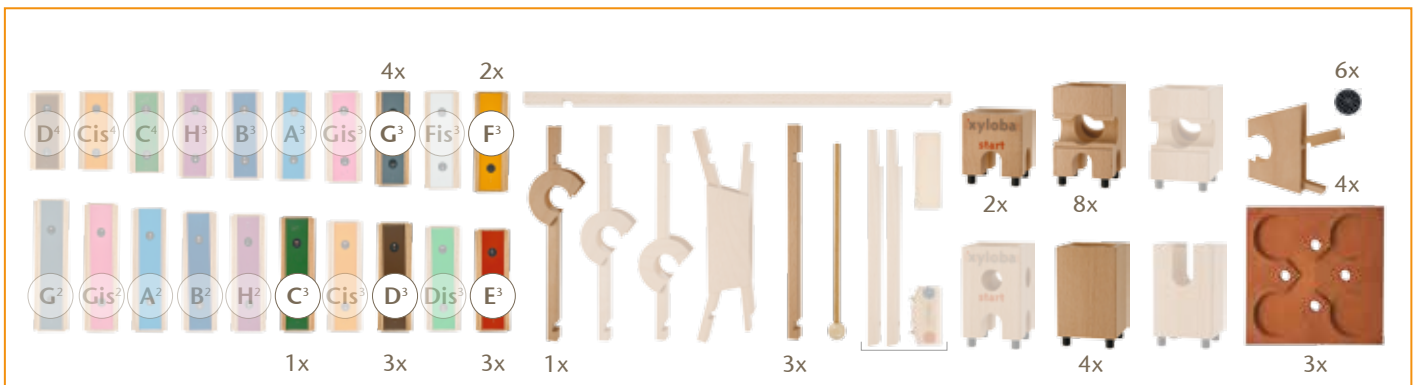

L'inverno l'è passato (Melodienanfang / first lines of familiar songs)

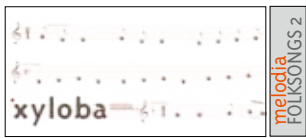

melodia folksongs 2

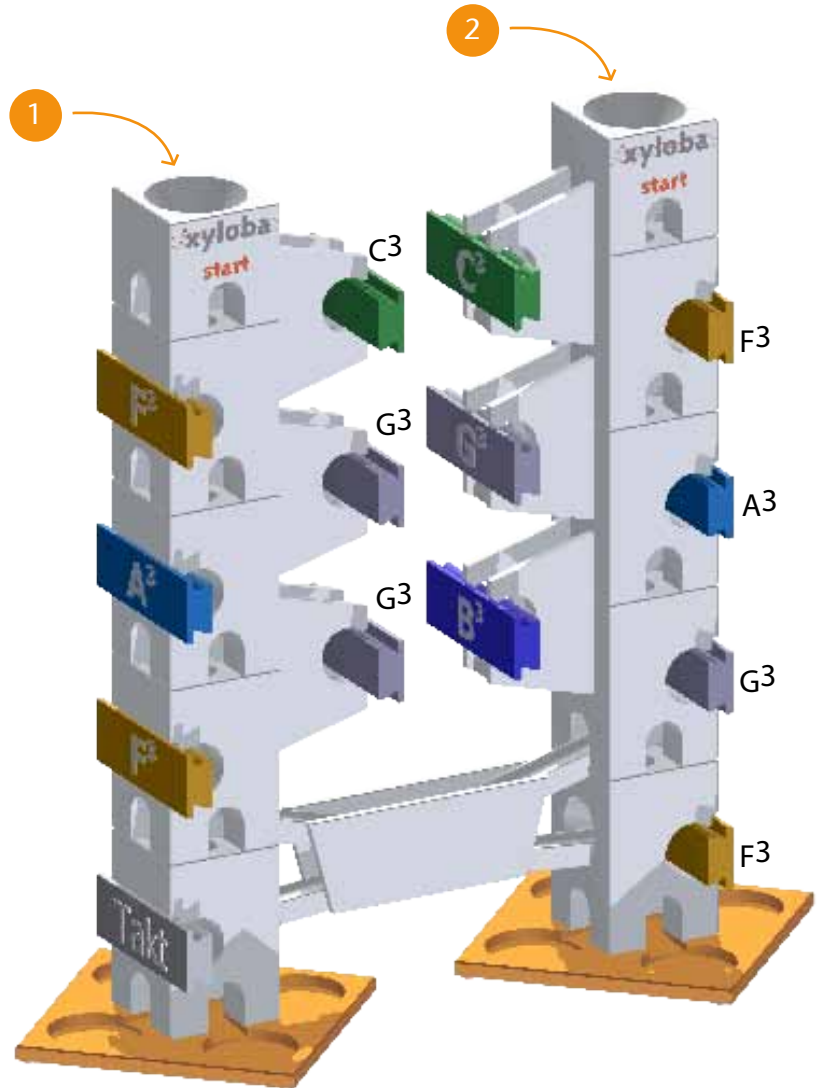

Diese Bauteile werden benötigt / required:

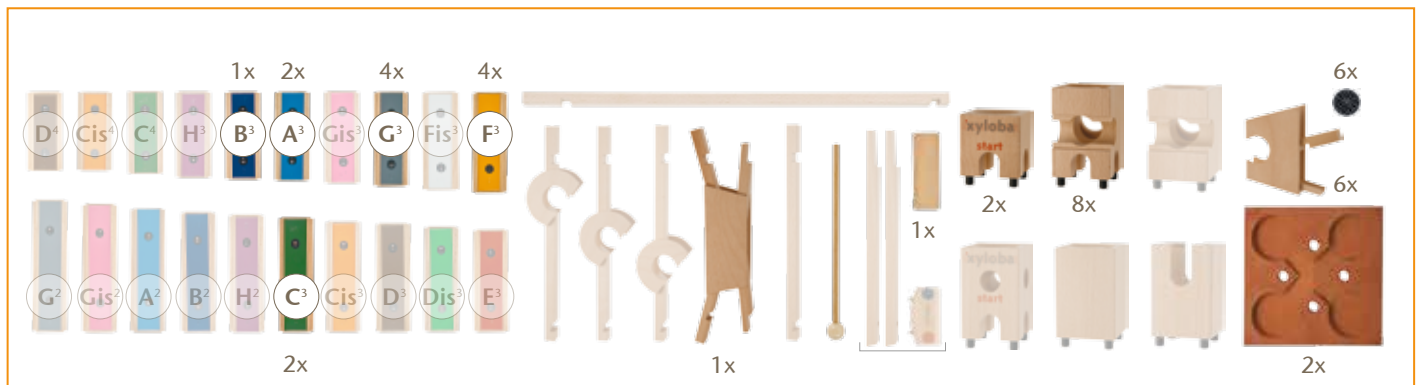

Xyloba Einzelteile / single components *(mehr Information auf /additional informations on www.xyloba.ch)*

Bauklotz/building brick



Art. 22201

Durchgangsklotz/
passage brick



Art. 22204

Klangklotz/
sound brick



Art. 22202



Rollbahn kurz & lang/Art. 22302/Art. 22301
rolltrack short & long



Weiche/points Art. 22072

Kugeln (Glaskugeln, Holzkugeln und Experimentierkugeln)/glass marbles, wooden marbles, experimental marbles

Art. 22051



Art. 22052



Art. 22053



Rollbahn Achtel/
roll track one eighth



Rollbahn Achtel
Triole/roll track
one eighth triplet



Rollbahn Achtel
punktirt/roll track
one eighth dotted



Klangklotz ohne
Bahnausgang/sound-
brick without track exit



Art. 22203

Startklotz im Turm/
start brick in the tower



Art. 22206

Startklotz/start brick



Art. 22205

Xylophon/glockenspiel
Art. 22031



Bauteil Achtelnote/
building element
eighth note



Art. 22303

Rollbahn Kreuzung/roll track crossing Art. 22307



Einzelton Takt/
single sound stroke

Art. 22308



Klangplatte/sound plate

Art. 22041. G2 bis D4



Grundplatte/base plate Art. 22207



Xyloba für Einsteiger / for beginners



Art. 22011 - 25 Teile / parts

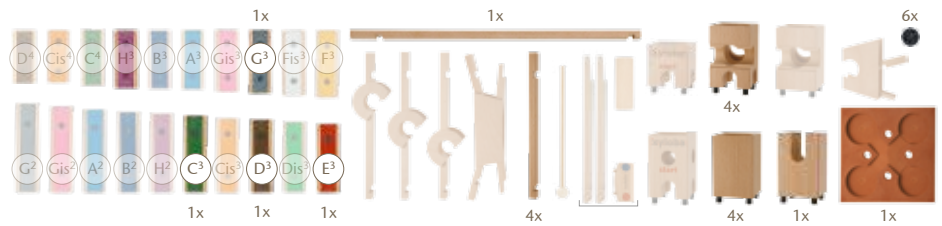

Art. 22012 - 40 Teile / parts

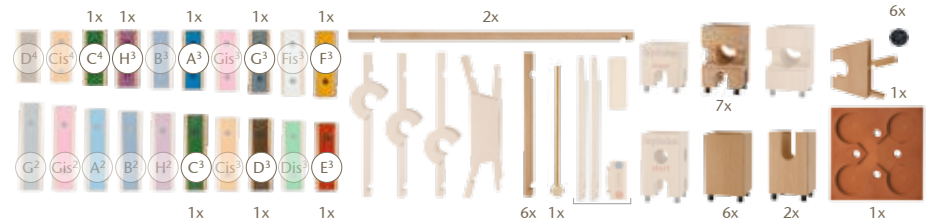

Art. 22013 - 96 Teile / parts

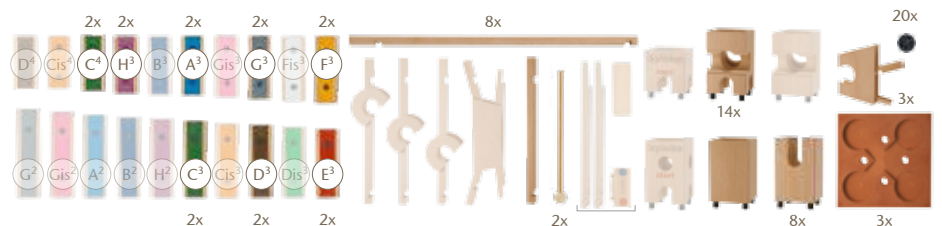

Xyloba Erweiterungskästen / extensions

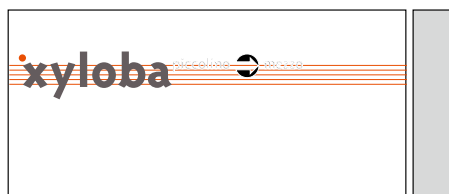

Art. 22014 - 22 Teile / parts

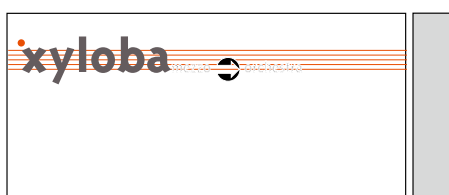
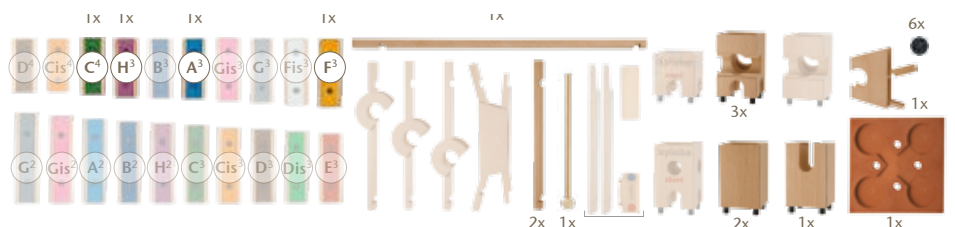

Art. 22015 - 62 Teile / parts

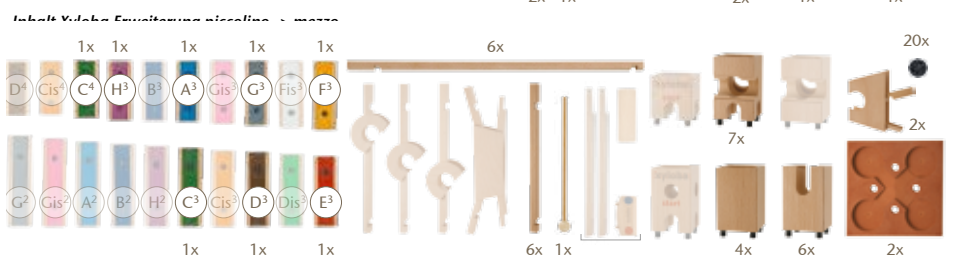

Xyloba Melodienbuch / melody booklet

Zwölf wunderschöne, komplette Melodien sind im Xyloba Melodienbuch enthalten, mit genauer Anleitung / 12 fantastic, complete tunes are included in the Xyloba melody booklet, with detailed instructions.

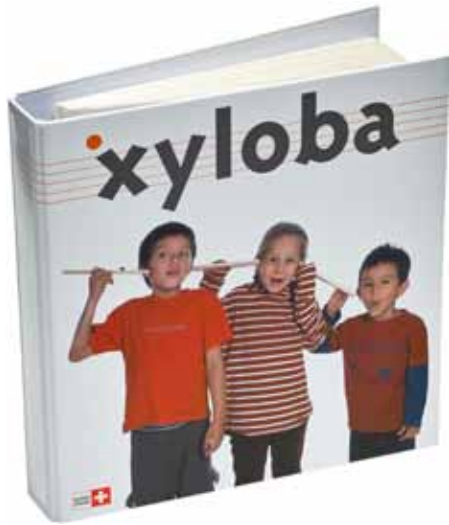

Art. 22401.de



Xyloba Melodienbahnen / melody tracks

Zwölf komplette Melodien / twelve complete melodies

1. Frère Jacques	Art. 22601	56 Teile
2. Row, row, row your boat	Art. 22602	59 Teile
3. Sur le pont d` Avignon	Art. 22603	69 Teile
4. Summ, summ, summ	Art. 22604	53 Teile
5. Der Mond ist aufgegangen	Art. 22605	89 Teile
6. Bella Bimba	Art. 22606	123 Teile
7. Happy Birthday	Art. 22607	75 Teile
8. Weisst du, wieviel Sternlein stehen	Art. 22608	72 Teile
9. Hänschen klein	Art. 22609	84 Teile
10. L`inverno l`è passato	Art. 22610	92 Teile
11. Oh, when the Saints	Art. 22611	96 Teile
12. Stille Nacht	Art. 22612	176 Teile
13. Melodien-Komplett-Set/Master-set*	Art. 22600	238 Teile

*mit diesem Set können alle 12 Melodien vollständig aufgebaut werden/ this set allows you to fully build all 12 tunes..

Xyloba Töne/tones (Alle Melodien bei Xyloba erklingen zwei Oktaven höher als notiert/all Xyloba tunes play two octaves higher than written)

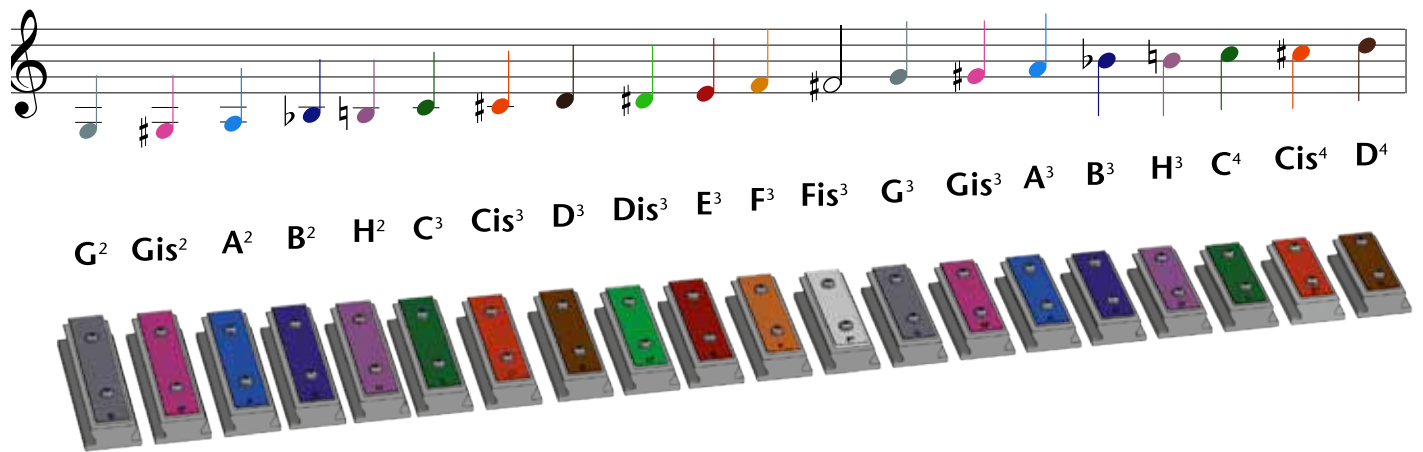

www.xyloba.ch - Xyloba - Die Kugelbahn, die Musik macht
www.xyloba.com - The marble run, that makes music



Erfinder/inventor: Samuel Langmeier, Zürich (Switzerland)

Xyloba wird aus 100 % naturbelassenem Buchenholz gefertigt/Made from 100 % natural beech wood.

Jedes einzelne Teil wird in unseren Werkstätten in liebevoller Handarbeit gefertigt/Hand-made and packaged with loving care in our workshops.

Weizenkorn · Oetlingerstrasse 81 · CH-4057 Basel · www.weizenkorn.ch

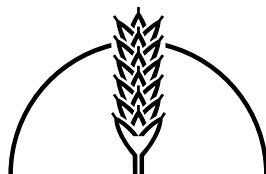

Weizenkorn

swiss handmade

